



Lifting Module Basic

Max. lifting force 1,000 N, stroke from 200 to 600 mm, manual-hydraulic version



Application

Lifting module for ergonomic design of working places.

Principal use

- Industrial assembly working places
- Height adjustment of assembly working places in workshops
- Maintenance works
- Assembly fixtures
- Adjusting systems in supply processes of mid-sized objects
- Handling systems for product packing and transfer

Fixing and installation

For fixing of *modulog* modules or other components of the user at the top plate the lifting module has an interface 140 x 140.

For fixing of *modulog* modules at the bottom plate the lifting module has an interface 200 x 200.

If the lifting module has to be fixed on a flat level floor, 4 screws M10 of property class 10.9 as well as heavy-duty plugs have to be used.

For increased stability also a base plate, which can be delivered as accessory, can be fixed at the bottom plate.

Advantages

- Elegant and slim design
- Optimised ergonomics
- Simple operation
- No coupling stroke required
- Working in ergonomically optimum height

Description

The stroke movement is obtained by a hydraulic linear unit with single-lever actuation with oil being pumped by means of a piston pump into a plunger cylinder.

For lowering the oil returns by the weight of the load from the cylinder back to the reservoir.

The lifting units are ideal for height adjustment of tables, demonstration objects and similar equipments as well as for medical treatment equipments.

Operation

To lift the load, the foot pedal has to be depressed by approx. 45° several times. The pedal returns to its off-position by means of a return spring.

For a stroke of 100 mm 8 pump motions are required.

To descend the load, the foot pedal has to be moved upwards by approx. 10°.

Material

Lifting profile:	aluminium, naturally anodised
Top and bottom plate	aluminium, black anodised

modulog

Lifting module



Part-no. 8910-01-X0-H

Technical characteristics

Max. lifting force: 1,000 N
 Max. torque: 100 Nm
 Stroke: 200 up to 600 mm

Operations

- Foot pedal



Combinable with the modules

- Rotating module - horizontal axis DMH 200 as per data sheet M 1.101 and M 1.102



- Tilting module KMB 100 as per data sheet M 2.101



- Rotating module - vertical axis DMV 1000 as per data sheet M 3.101 and M 3.102



- Cart modules WMS as per data sheet M 5.101



- Floor modules FMS as per data sheet M 6.101



modulog interfaces

- Top plate: 140 x 140 - Ø 10.5 mm
- Bottom plate 200 x 200 - Ø 10.5 mm

Accessories

- Base and adaptor plates as per data sheet M 8.100 and M 8.110
- Table plates as per data sheet M 8.130

Technical characteristics Dimensions

Technical characteristics

Stroke [mm]	A [mm]	A+Stroke [mm]	Weight [kg]
200	420	620	9.5
300	520	820	10
400	620	1020	11.5
500	720	1220	13
600	820	1420	14.5

Important notes!

To descend the lifting module a minimum load of approx. 200 N is required.

The lifting module must only be pressure loaded. The centre of gravity should be within the traverse of the fixing screws.

If the centre of gravity is outside, the dowelled joint with the floor has to be dimensioned correspondingly. In such cases it is recommended to use a larger base plate.

In case of eccentric load of more than 250 mm, the column cannot descend automatically because of too high friction forces.

The lifting module is designed for applications within closed rooms.

Code for part numbers

Part-no. **8910-01-X0-H**

Stroke

- 2** = 200 mm
- 3** = 300 mm
- 4** = 400 mm
- 5** = 500 mm
- 6** = 600 mm

Dimensions

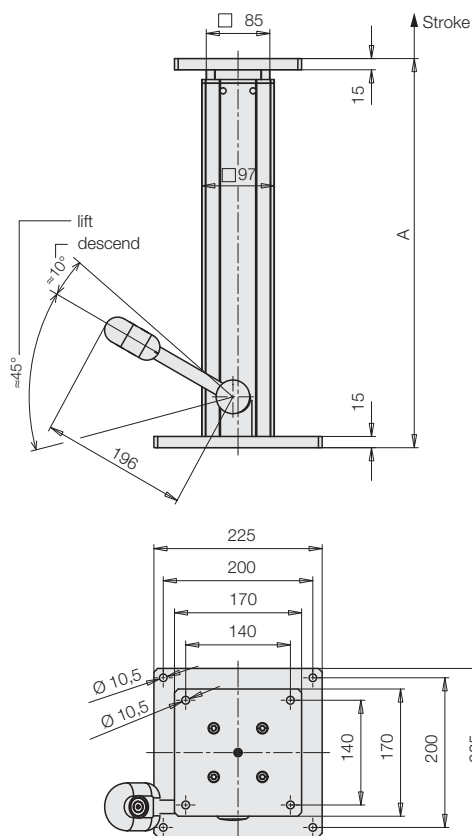

Maximum lifting force and maximum admissible torque load

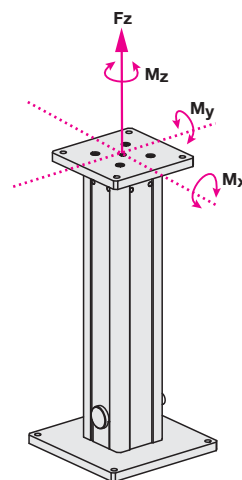

Maximum lifting force F_z : 1,000 N

Maximum torque load:

Total $M_{x/y}$: 100 Nm

M_z : 50 Nm

In the case of eccentric loads, it is recommended to compensate these by counterweights. In off-position the indicated maximum torques may occur.

The forces and torques have to be considered by the operator. During the lifting motion only 50% of the maximum values are admitted.

Accessories

Base plate for increased stability

Part-no.: 6311-412

See data sheet M 8.100