



Lifting Modules Twin-Strong

Max. lifting force 4,000 and 6,000 N, stroke from 200 to 400 mm, manual-hydraulic and electro-mechanical version



Advantages

- Lifting force up to 6,000 N
- Extreme load due to double steel guides
- Very high section modulus
- Rigid guiding system without clearance
- Sturdy and tough
- Compact design
- Modular standard design, easy to combine
- Less load on the operator due to ergonomic design
- Safe and precise handling
- Safety factor 2.0 against static overload

Application

Lifting module for extreme loads.

Principal use

- Industrial production with difficult application conditions
- Automotive industry
- Assembly of car seats
- Drive technology, axes, cardan shafts
- Compressors, hydraulic elements, pumps
- Turbines, motors, gearbox construction
- Applications with frequent load changes and high torque loads

Fixing and installation

For fixing of *modulog* modules or other components of the user at the top plate, the lifting module has a triple interface 140 x 140.

For fixing of the lifting module on a flat level floor, the lifting module has a double interface 200 x 200. For fixing, 6 screws M10 of property class 10.9 as well as heavy-duty plugs are to be used.

Description

The lifting module Twin-Strong has two high-tensile cylinder tube profiles with chromium-plated surfaces. The design with solid profiles allows a stable guiding system with perfect smooth running. The high precision of the profiles permits a guiding system without clearance and perfect smooth running.

The guiding system works without fat and oil lubrication. High-quality materials for plain bearings are used.

Characteristic are applications with indifferent, dynamically swelling rotating motions and shock motions.

Material

Double guiding system, top and base plates are made of steel. Materials for plain bearings are made on the base of polymers.

modulog

Lifting module

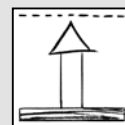

Part no. 8914-06-X0-X

Technical data

Max. lifting force:	4,000, 6,000 N
Max. torque:	2,000 Nm
Stroke:	200 to 400 mm

Operations

- Foot pedal
- Foot switch
- Hand panel



Combinable with the modules

- Rotating modules – horizontal axis
DMH 200 as per data sheet M 1.101,
DMHe 200 as per data sheet M 1.201
- Tilting modules
KMB 100 as per data sheet M 2.101
KME 100 as per data sheet M 2.201
- Rotating modules – vertical axis
DMV 600 as per data sheet M 1.301,
DMVe 600 as per data sheet M 1.201



modulog interfaces

- Top plate: 140 x 140 - Ø 10.5 mm
- Bottom plate 200 x 200 - Ø 10.5 mm

Accessories

- Electronic control modules for 1, 2, 3 or 4 lifting modules as per data sheet M 8.200
- Control modules with battery holder as per data sheet M 8.201
- Electrical operating elements, lines and connectors as per data sheet M 8.203
- Base and adaptor plates as per data sheet M 8.100 and M 8.110
- Table plates as per data sheet M 8.130 and M 8.131

Manual-hydraulic version Operation with foot pedal



Description

The stroke movement is obtained by a hydraulic lifting jack with single-lever actuation, with oil being pumped by means of a piston pump into a plunger cylinder.

During retraction the oil returns due to the weight of the load from the cylinder back to the reservoir. A defined speed reduction is effected.

The manual-hydraulic variant is particularly sturdy and durable. This variant meets high safety demands and withstands jerking and knocking loads in applications.

Code for part numbers

Part no. 8914-0X-X0-H

Maximum lifting force _____

4 = 4,000 N

6 = 6,000 N

Stroke _____

2 = 200 mm

3 = 300 mm

4 = 400 mm

Operation

To lift the load, the foot pedal has to be depressed by approx. 40° several times. The pedal returns to its off-position by means of a return spring.

To lower the load, the foot pedal has to be moved upwards by approx. 10°.

Maximum lifting force and maximum admissible torque load

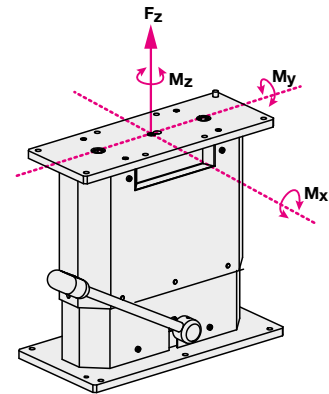

Dimensions

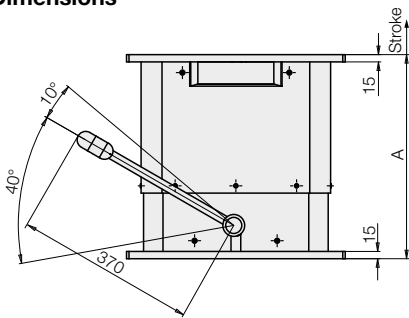

Technical data

Stroke [mm]	A [mm]	A + stroke [mm]	Weight [kg]
200	420	620	95
300	520	820	100
400	620	1020	105

Lifting force [N]	Pump strokes per 100 mm	Descent speed [mm/s]
4,000	7	approx. 22
6,000	9	approx. 22

Maximum torque load:

M_x: 2000 Nm or **M_y**: 1200 Nm
M_z: 600 Nm

In the case of eccentric loads, it is recommended to compensate these by counterweights. In off-position, the indicated maximum torques may occur.

The forces and torques have to be considered by the operator. **During the lifting motion, only 50 % of the maximum values are admitted.**

Accessories

Base plate for increased stability as per data sheet M 8.100

Important notes!

To descend the lifting module a minimum load of approx. 200 N is required.

The lifting module must only be pressure loaded. The centre of gravity should be within the traverse of the fixing screws. If the centre of gravity is outside, the dowelled joint with the floor has to be dimensioned correspondingly. In such cases it is recommended to use a larger base plate.

In case of eccentric load of more than 250 mm, the column cannot descend automatically because of too high friction forces.

The lifting module is designed for applications within closed rooms.



Description

The lifting motion is generated by an electric motor with a self-locking spindle lifting gear. The electrically operated variant is particularly suitable for positioning and adjusting tasks of working tables as well as for material supply and transport. They excel by a smooth running.

Operation

Lifting and lowering with hand panels or foot switches as per data sheet M 8.203 is triggered by touch control. After release of the push-button, the motion will be immediately stopped. The hand panel with memory function allows to store 5 positions, which can be approached via corresponding position push-buttons. (for detailed description see data sheet M 8.203)

Code for part numbers

Part no. **8914-0X-X0-X**

Maximum lifting force _____
 4 = 4,000 N
 6 = 6,000 N

Stroke _____
2 = 200 mm
3 = 300 mm
4 = 400 mm

Electronics

E = integrated stroke end disconnection (not suitable for synchronization control) with coiled connecting cable, 1.5 m
G = with incremental stroke measuring system (suitable for synchronization control) with smooth connecting cable, 2.5 m
I = with incremental stroke measuring system (suitable for memory function) with smooth connecting cable, 2.5 m

Dimensions

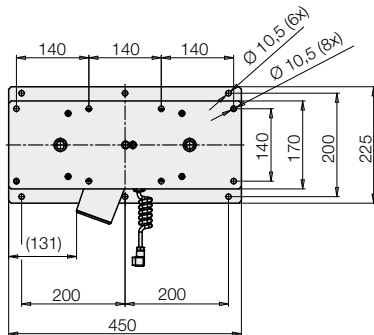
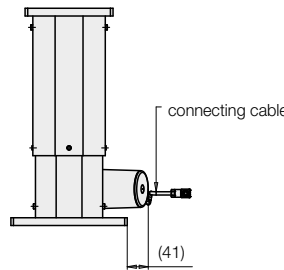
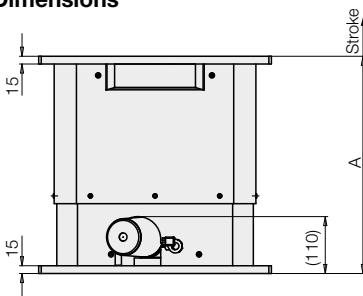

Technical data

Electric connection	Plug
Duty cycle	15 % ED
Code class	IP 54
Control voltage	24 V DC

Variante E and I

Lifting force	Lifting speed (load-dependent)	Current consumption (load dependent)
[N]	[mm/s]	[A]
4,000	10 ... 8	6
6,000	7 ... 5	7.5

Variant G

Lifting force	Lifting speed (load-dependent)	Current consumption (load dependent)
[N]	[mm/s]	[A]
4,000	8 ... 6	4.5
6,000	6 ... 4	5.5

Synchronization

Up to 4 lifting modules can be operated with synchronization control by a corresponding control module. For example complete lifting platforms can be designed.

For operation with synchronization control, only lifting modules with code letter G are suitable.

Control units with synchronization control for 2, 3, or 4 lifting modules are available.

Accessory

Base plate for increased stability as per data sheet M 8.100

Important notes!

- Maximum admissible torque load as per manual-hydraulic version (see page 2) .
- The maximum pull force of the electro-mechanical version is 80 % of the push force!

Delivery

The lifting modules are delivered ready for connection. The connecting cable from the lifting module to the control module is included in the delivery. Operating elements as well as control modules and mains cables can be ordered separately as an accessory.

Electrical accessories required for a functional system:

- Control module as per data sheet M 8.200 or
- Control module with battery holder as per data sheet M 8.201 (no fixing possibility at the lifting module)
- Hand panels, foot switch and mains cable as per data sheet M 8.203