

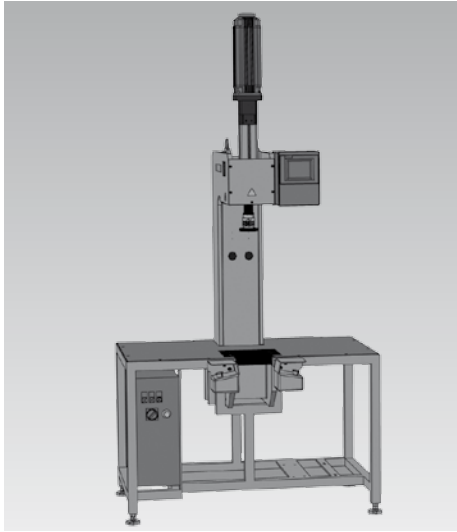

Press-In Devices in C-Frame Design

Electrical drive, max. press-in force 7 and 25 kN

creep/rapid speed control with optional force/stroke monitoring



Advantages

- High forces / rigid frames
- No cost and time-consuming project planning
- Short delivery times
- Easy retrofitting of functions or components
- Standardized drilling patterns for workpiece and tool holders provided by the customer
- Interchangeability of the individual elements by standardized drilling patterns
- Ergonomically designed operation
- Good workpiece feeding
- Reduction of the assembly time
- Process safety
- Sales of individual components

Application

These press-in devices are preferably used in assembly processes for the production of longitudinal pressed joints, riveted joints as well as for pressing out and testing of components.

Principal use

- Drive technology, gears box assembly
- Couplings, cardan shafts
- Compressors, pumps, hydraulic elements
- Industrial fittings
- Mechanical engineering
- Components for construction and agricultural machinery
- Electronics

Operation

For safety reasons, the press-in device is equipped with a two-hand operation. This has a divided design (two separate push-buttons) to allow workpiece feeding from the front. Alternatively, it is also possible to provide safety light grids or a protective covering. In such applications, function triggering is made by a push-button.

Description

The base frame is designed as a working table. Below the table plate there is the electric control that controls the electrical press-in cylinder at the C-frame.

The steel base plate of the C-frame is installed flush with the table plate in the working table, so that the working surface is plane and edges are avoided.

On the base plate any workpiece carriers such as sliding tables can be mounted.

The piston rod of the press-in cylinder is equipped with a quick-changing device, at which the press-in tools can be mounted. This can optionally be replaced by other tool holders.

Thanks to the modular design, the functions of the control as well as mechanical components can be easily exchanged or retrofitted. The stroke measurement is made by the evaluation of the integrated rotary encoder.

The force measurement (control variant 2) is made indirectly by a strain sensor at the press-in frame.

modupress

Press-in device



Part-no. 6420-3XX-XXX

Technical characteristics

Max. press-in force: 7, 25 kN
 Stroke: 100, 200, 300, 400 mm
 Actuation: electrical
 Frame type: C-frame

Control variant 1

Rapid/creep speed control

Control variant 2

Rapid/creep speed control with stroke/force monitoring

Operations

- Two-hand operation

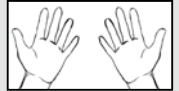

Data interfaces

- Ethernet/SD-card

modupress interfaces

- Base plate: 140 x 140 – 4 x M10, 2 x Ø 18H7
- Tool holder: In the bolt circle Ø 84 mm
4 counterbores M6

Accessories

- Workpiece feeders see data sheet P 9.100
- Tool holders see data sheet P 9.200

Alternative modupress modules

- Hydraulic press-in cylinder see data sheet P 3.200
- Pressure generator (power unit) see data sheet P 5.100

Control variants

ROEMHELD press-in devices are available by default with two control variants.

Control variant 1 (rapid/creep speed) or with control variant 2 (force/stroke monitoring).

Input and output functions

Control variant 1

Rapid/creep speed

Touch panel, 4 inch

- Setting mode and normal operation
- Select "Join to force" or "Join to position"
- Variable rapid/creep speed control by using a frequency converter
- Indication of the maximum press-in force or the position
- Hold time after joining
- Return position to return stroke limitation
- Management of the parameters in freely selectable records
- Evaluation of system errors

Control variant 2

Rapid/creep speed with force/stroke monitoring

Touch panel, 7 inch

- Setting mode and normal operation
- Select "Join to force" or "Join to position"
- Variable rapid/creep speed control by using a frequency converter
- Indication of the maximum press-in force or the position
- Hold time after joining
- Return position to return stroke limitation
- Management of the parameters in freely selectable records
- Evaluation of system errors
- Parameterisation of max. 4 evaluation windows per record (optionally envelope possible)
- Graphical representation (force/stroke diagram) of the press-in process
- About 100 records can be stored
- Logging and archiving of the press-in process
- Various evaluation options, separate batch counters (good/bad), statistical distribution, etc.

Graphical representation of the press-in process

One record consists of:

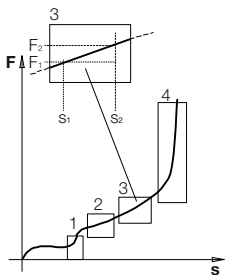

- Position - off-position
- Position - switching rapid/creep speed
- Max. force
- Min. force
- Max. stroke
- Min. stroke

For the data output of the specified and measured values, the interfaces for Ethernet and SD card are available.

Functional description

Normal operation (press-in operation)

Control variant 1 and 2

After function triggering, the press-in cylinder extends first at rapid speed. After reaching the defined switching point, the speed will be reduced to creep speed.

Join to force:

After reaching the set maximum force and the subsequent hold time, the press-in cylinder retracts to the defined return position.

Join to position:

After reaching the set position, the press-in cylinder retracts to the defined return position.

Setting mode

Control variant 1 and 2

When selecting "setting mode" at the touch panel, the press-in cylinder can be extended or retracted by manual control. Thus it is for example possible to approach workpiece-specific points, read positions to enter these as parameters.

The press-in cylinder moves with touch control (i.e. only when the push-buttons are pressed) and only in creep speed.

Additional functions

Control variant 2

By means of the touch panel for one of the possible 100 data records the desired press-in forces with the associated stroke points and their admissible limit values are entered and represented on the screen in the form of force/stroke windows.

The press-in force is permanently measured with the force transducer and the stroke of the press-in cylinder is determined with the stroke measuring system via the rotary encoder. At any preset force/stroke point, the measured values are compared with the admissible limit values.

If one or several measured values are outside the admissible limit values, a NIO error message appears immediately (NIO = not in order).

In order to make a new pressing, the error message at the touch panel must be reset first. If all the measurements are within the set limit, an IO message appears immediately and the next pressing can be effected (IO = in order).

Code for part numbers - C-frame electrical

6 4 2 0 - 3 X X - X X X

Clear depth

- 1 = 220 mm
- 2 = 330 mm

Clear height

- 1 = 300 mm
- 2 = 460 mm
- 3 = 680 mm

Press-in force

- 1 = 7 kN
- 2 = 25 kN

Stroke

- 1 = 100 mm
- 2 = 200 mm
- 3 = 300 mm
- 4 = 400 mm

Control variant

- 1 = Rapid/creep speed
- 2 = Force/stroke monitoring

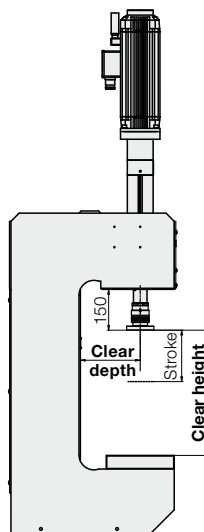

Example of ordering

6420-313-212 = C-frame,
clear depth 220 mm,
clear height 680 mm,
25 kN,
stroke 100 mm,
force/stroke monitoring

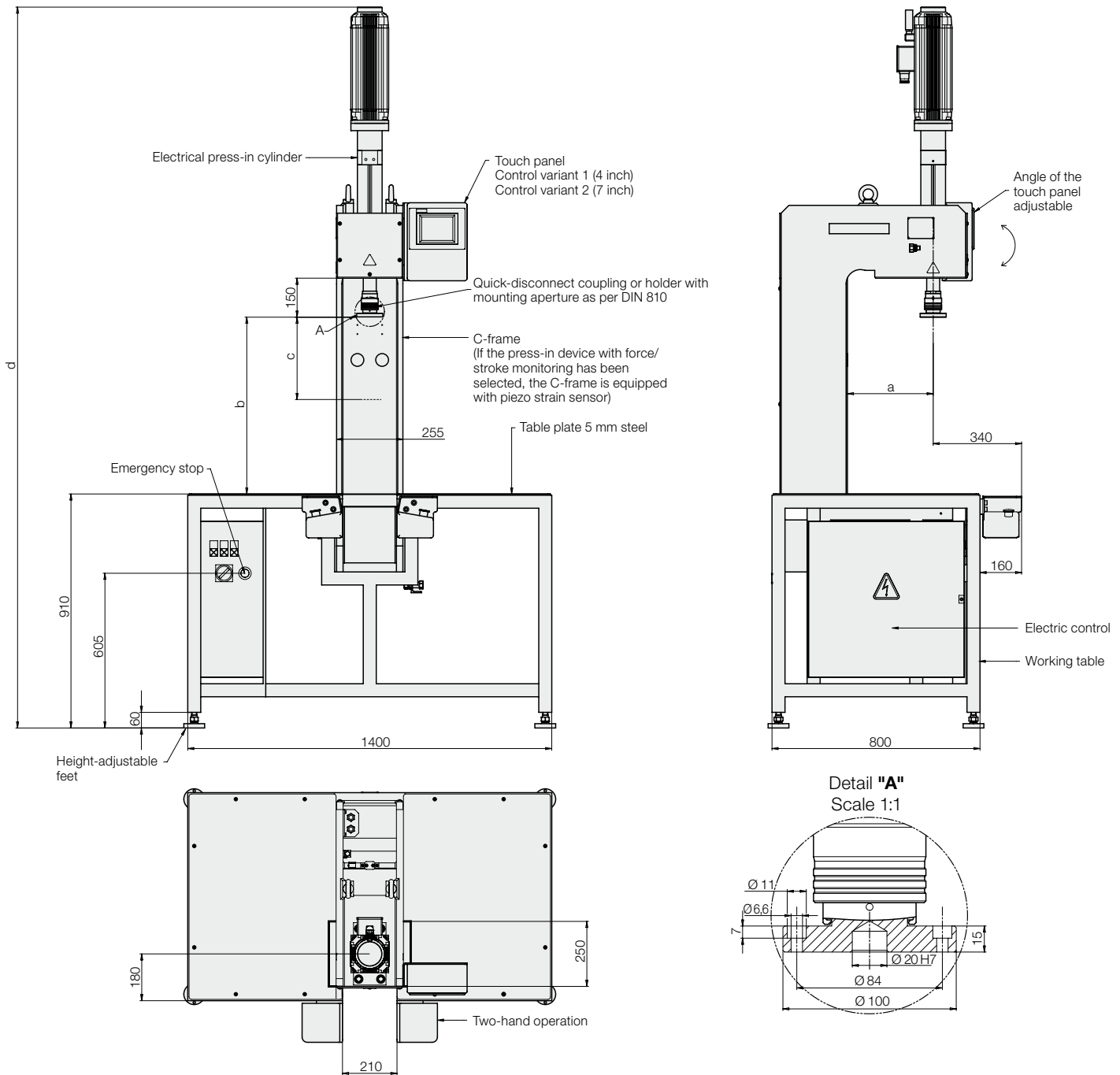

Technical characteristics

Press-in force	[kN]	40 / 63 / 100
a = clear depth	[mm]	220 / 330
b = clear height	[mm]	300 / 460 / 680
c = cylinder stroke	[mm]	100 / 200 / 300 / 400
d = total height	[mm]	1450 + b + stroke
Accuracy stroke measuring system*	[mm]	± 0.2
Accuracy force measurement	[kN]	2 % calibrated final value
Creep speed	[mm/s]	approx. 10–30
Rapid speed	[mm/s]	approx. 75–100

Base plate

