



Built-in Pistons
single acting, with spring return
max. operating pressure 250 bar



Advantages

- Low built-in height
- Very compact design
- Extremely low overall height, despite return spring and fully utilisable stroke limitation
- Easily exchangeable
- High force density

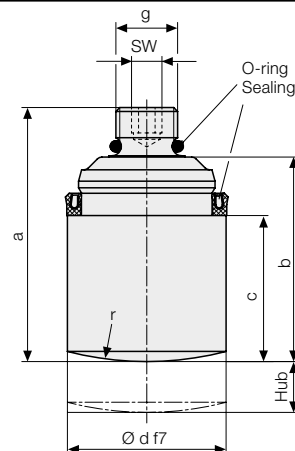

Technical data

Max. operating pressure 250 bar

Clamping force at 250 bar	[kN]	12.25	20	31.25	48.75
Clamping force at 100 bar	[kN]	4.9	8	12.5	19.5
Spring return force, min.	[N]	130	200	230	400
Piston Ø d	[mm]	25	32	40	50
Stroke	[mm]	8	8	8	12
Total oil volume	[cm ³]	4	7	10	24
a	[mm]	40	47	50	75
b	[mm]	32.5	34.5	36	56
c	[mm]	23.5	25	26	43
e	[mm]	11.5	14	19.5	24
f	[mm]	32	42	47	58
g	[mm]	G 1/8	G 1/4	G 3/8	G 1/2
r	[mm]	50	100	150	200
SW	[mm]	4	6	6	8
Tightening torque	[Nm]	10	20	25	30
Weight	[kg]	0.10	0.17	0.28	0.59
Part no.		1072010	1073010	1074010	1075020

Application

Built-in pistons are used in bars and blocks for clamping and locking of workpieces and dies. The built-in pistons are particularly suitable for narrow and flat installation spaces due to their compact design.

Description

Plunger piston, single acting, with integrated return spring, stroke limitation and fixing screw form a subassembly that cannot be disassembled.

Sealing ring made from PTFE, O-ring as static seal. Piston hardened and ground. On request, a wiper ring is supplied for installation in the housing. Special seals on request.

Important notes!

Lateral forces less than 5 % of clamping forces. To ensure perfect operation, the installation dimensions and surface qualities must be strictly observed.

Use Allen key for assembly and disassembly. Replace O-ring after disassembly. Max. operating temperature 80 °C. Use Loctite no. 242 to secure thread.

Application example

Built-in piston integrated in a clamping bar

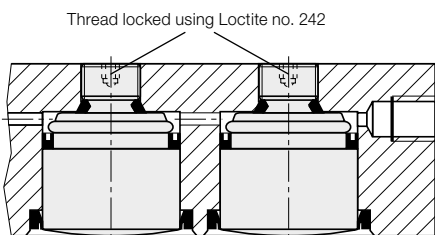

Hydraulic power units
see product group 7

Hydraulic accessories
see product group 11

Location hole

Hydraulic oil supply through holes drilled in the base. Only one oil port is required.

Mounting sleeve

for built-in piston and wiper ring

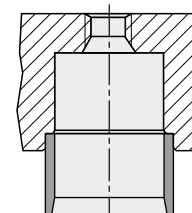
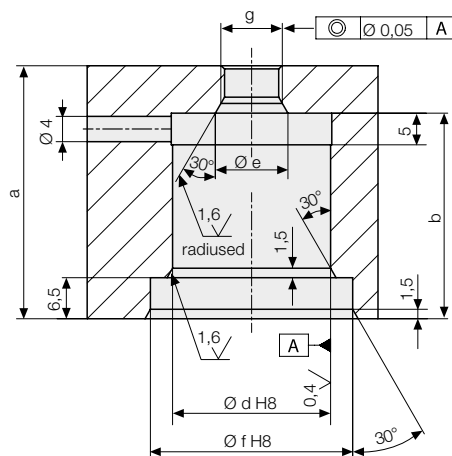

Wiper ring

