



Hollow Piston Cylinders
single acting, with spring return
max. operating pressure 400 bar



Advantages

- Flat and compact design
- Jerkless piston movement
- Stroke limitation designed for max. operating pressure
- Easy to retrofit
- Ideal force transmission

Description

Installation is possible by insertion or manifold mounting in any position. The clamping force is generated by applying hydraulic pressure to the piston, and the piston is returned by a spring. The piston is provided with a through hole and is hardened and ground. The housing of the hollow-piston cylinder is made of high alloy steel, the surface is black oxidized.

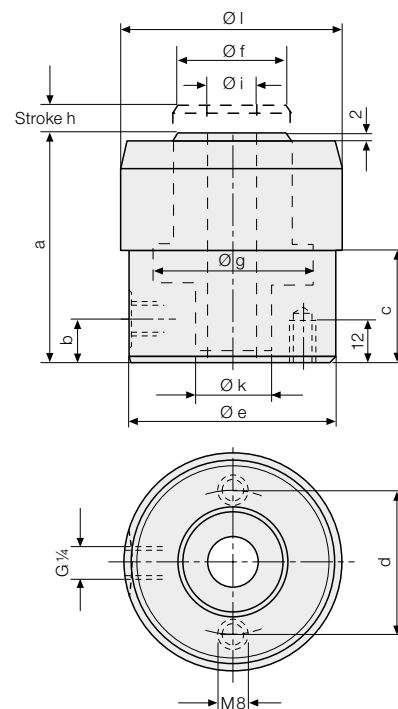

Application

Hollow piston cylinders are used in connection with tie rods, screws and threaded rods, for clamping and locking dies on presses and machines.

Hydraulic power units

see product group 7

Accessories

see product group 11

Technical data

Max. operating pressure 400 bar

Clamping force at 100 bar	[kN]	8.7	13.5	21	34.3
Clamping force at 400 bar	[kN]	34.8	54	84	137.2
Stroke h	[mm]	12	12	15	15
Spring return force	[kN]	0.26	0.36	0.50	0.75
Piston area	[cm ²]	8.7	13.5	21	34.3
Oil volume per 1 mm stroke	[cm ³]	0.9	1.4	2.1	3.5
a	[mm]	76	76	97	97
b	[mm]	11	15	18.5	24
c	[mm]	38	38	41	41
d	[mm]	44	55	68	84
e	[mm]	60	75	93	113
f	[mm]	28	38	45	58
g	[mm]	40	50	63	80
i	[mm]	16.5	20.5	24.5	30.5
k	[mm]	22	28	36	45
l	[mm]	60	80	100	120
Weight	[kg]	1.3	2.2	4.2	6.1

Part no.

1323003 1325003 1327003 1329003

Special versions on request

Application examples

