



Flexline Rapid Clamping System with Push Chain

Flexible selection of clamping element, T-slot and adjustment track electrically or pneumatically driven



Advantages

- 8 different clamping elements
- 4 different T-slots
- 3 different adjustment tracks
- Electrical or pneumatic drive motor
- Easy to service, easily exchangeable modular assemblies ensure high availability of parts
- Technical design and finished drawing in just a few minutes
- Highly flexible, low-maintenance hydraulic hoses with high burst pressure

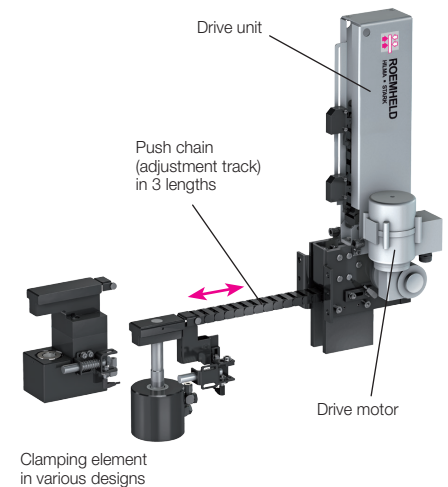

Application

Rapid clamping systems are used for the automatic clamping of dies of varying sizes on the press ram.

Description

The electrically or pneumatically driven push chain moves the clamping element attached to the rapid clamping system automatically from the parking position to the clamping position at the clamping edge and then back to the parking position.

The T-slot of the machine serves as the guide for the push chain and clamping element. The push chain also serves as the energy chain for accommodating the hydraulic and electric lines of the clamping element.

Versions

Flexline rapid clamping systems can be supplied in the following variants:

- **Clamping elements**
Hollow piston cylinders, clamping cylinders with locking mechanism, spring clamping cylinders or sliding clamps
- **T-slots** 28, 32 or 36 mm or 1 1/16"
- **Adjustment tracks** (tracks of the clamping element) 660, 820 or 1100 mm
- **Drive motor** electrical or pneumatic
- **Optional position monitoring** (adjustable)
micro switch for "end position" and "intermediate position"
- **Position monitoring of the "die position"** attached on the left or right hand side
- **Chain case** in galvanised design or painted individually at customer's request
- **Option: Design with UL-compliant components**
- **Various Harting connectors** to choose from for motor current and monitoring signals
- **Option: Socket housing** for assembly to machine

Technical data

T-slot	28 mm and 36 mm (DIN 650) / 32 mm (similar to DIN 650) and 1 1/16"
Adjustment speed	150 mm/s
Multi-frequency motor	400 V 50 Hz and 480 V 60 Hz / 3~ AC
Motor current	0.18 A
Motor rating	45 W
Motor connection	Harting connector with 500 mm cable length
Monitoring connection	Harting connector with 500 mm cable length
Monitoring:	
1. Parking position	inductive sensor 24 (10–30) V DC
2. Die position	inductive sensor 24 (10–30) V DC
Option:	
3. "End position" (end of chain)	micro switch
4. "Intermediate position"	micro switch
Hydraulic connection	8 mm pipe socket with union nut M 16x 1.5 (500 mm hose length)
Operating temperature	max. 70 °C
Option drive motor	pneumatic motor direct current motor 24 V DC single-phase alternating current motor 115 VAC, 60 Hz
Part no.	8228 (basic version)

Application example



Product selection

Selection scheme

You can configure the desired product variant yourself. You are provided with a dimension drawing for the selected configuration and can send us your chosen configuration directly for an offer to be prepared.

Clamping element	Dimensions D x L	Clamping force	Operating pressure	Total stroke S	Clamping stroke St	Oil volume clamping/unclamping
<input type="radio"/> Hollow-piston cylinder, double acting	Ø 95 x 88	104 kN	400 bar	12 mm	8 mm	2.6/2.6 cm ³ /mm
<input type="radio"/> Hollow piston cylinder, single acting	Ø 90 x 105	104 kN	400 bar	12 mm	8 mm	2.6/ – cm ³ /mm
<input type="radio"/> Hollow-piston cylinder, double acting	Ø 105 x 88	100 kN	245 bar	12 mm	8 mm	4.1/4.1 cm ³ /mm
<input type="radio"/> Hollow piston cylinder, single acting	Ø 100 x 112	100 kN	245 bar	12 mm	8 mm	4.1/ – cm ³ /mm
<input type="radio"/> Clamping cylinder, double acting, with locking	Ø 100 x 128	100 kN	100 bar	8 mm	4 mm	31/31 cm ³ /mm (22 cm ³ for adjustment stroke 0–3 mm)
<input type="radio"/> Spring clamping cylinder, single acting	Ø 120 x 134	100 kN	260 bar	7 mm	1 mm	–/7.9 cm ³ /mm
<input type="radio"/> Sliding clamp, double acting	80 x 75	78 kN	400 bar	12 mm	8 mm	2/1.5 cm ³ /mm
<input type="radio"/> Sliding clamp, single acting	80 x 75	78 kN	400 bar	12 mm	8 mm	2 cm ³ /mm

Slot width	Max. track of the clamping element V
<input type="radio"/> 28 mm (DIN 650)	<input type="radio"/> 660 mm (H = 574 mm)
<input type="radio"/> 32 mm	<input type="radio"/> 820 mm (H = 654 mm)
<input type="radio"/> 36 mm (DIN 650)	<input type="radio"/> 1100 mm (H = 794 mm)
<input type="radio"/> 1 1/16" (27 mm)	

Motor	R
<input type="radio"/> 400 V ± 10 %, 50 Hz, 3~ AC / 480 V ± 10 %, 60 Hz, 3~ AC	131 mm
<input type="radio"/> 400 V ± 10 %, 50 Hz, 3~ AC / 480 V ± 10 %, 60 Hz, 3~ AC (UL compliant)	131 mm
Optional extra	
<input type="radio"/> Pneumatic motor	119 mm
<input type="radio"/> Direct current motor 24 V DC	119 mm
<input type="radio"/> Single-phase alternating current motor 115 VAC, 60 Hz	131 mm

Position monitoring	Chain case
<input type="radio"/> Die position S2 - left	<input type="radio"/> galvanised, unlacquered
<input type="radio"/> Die position S2 - right	<input type="radio"/> lacquered RAL XXXX
<input type="radio"/> End position S3 + spec. of dimension K	
<input type="radio"/> Intermediate position S4 + spec. of Z dimension	

Harting connector for motor and position monitoring	
<input type="radio"/> Harting HAN modular 3x5 ES	Pin assignment type 2290
<input type="radio"/> Harting HAN 3 HvE / HAN 10 E	<input type="radio"/> Harting HAN 3 HvE / HAN 10 E "2290"
<input type="radio"/> Harting HAN 6 ES / HAN 10 ES	<input type="radio"/> Harting HAN 6 ES / HAN 10 ES "2290"
<input type="radio"/> Counterparts included in the delivery (selectable option: yes/no)	
Option	
<input type="radio"/> Harting HAN 10 ES (for pneumatic motor and 24 VDC motor)	
<input type="radio"/> Harting HAN 6 ES / HAN 10 ES (for single-phase alternating current motor 115 VAC, 60 Hz)	

Clamping dimension	Specification of clamping dimension F (±St/2) in [mm]
F = mm	F = c + m (m = die clamping edge, c = web height of T-slot)

F min. 70 mm, max. 128 mm for hollow piston cylinder
 F min. 70 mm, max. 112 mm for spring clamping cylinder and clamping cylinder with locking
 F min. 72 mm, max. 128 mm for sliding clamp + T-slot 28 + 1/16"
 F min. 77 mm, max. 128 mm for sliding clamp + T-slot 32
 F min. 82 mm, max. 128 mm for sliding clamp + T-slot 36

Sliding clamps

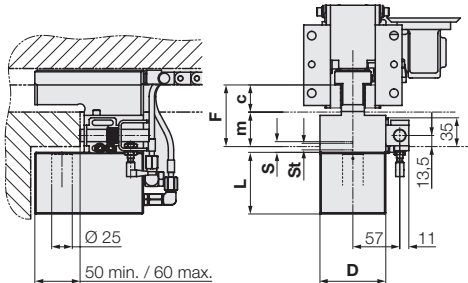

Cylindrical clamping elements

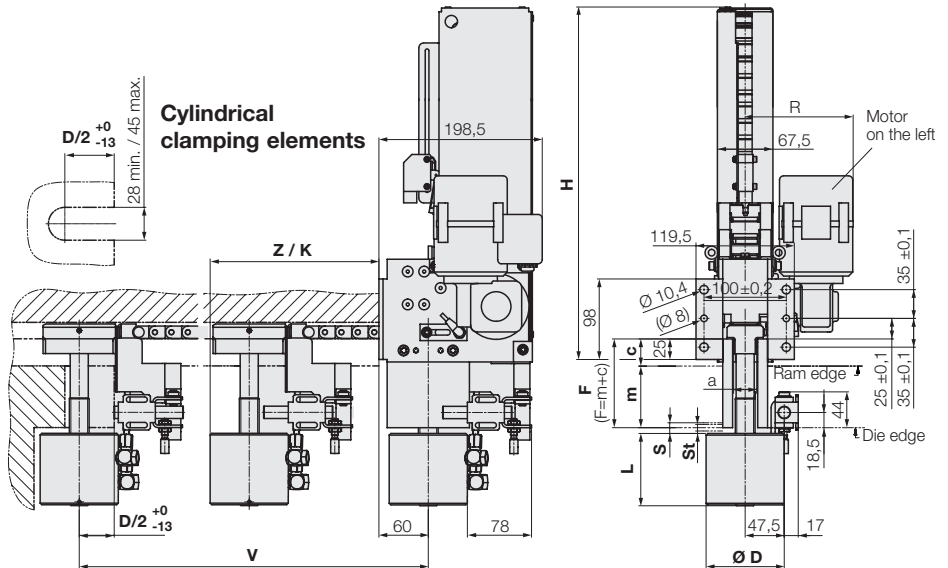

Clamping cylinder, double acting, with locking

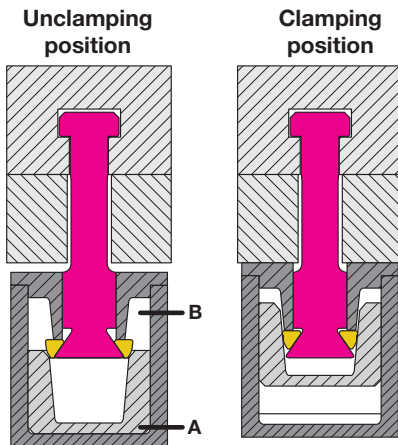

Functioning

To clamp, apply pressure to port A. The clamping element is moved by means of the integrated wedge mechanics to the edge of the die in a rapid adjustment stroke. After generating clamping force of 100 kN with only 100 bar operating pressure, the clamping position is then mechanically secured in a self-locking manner, so that the clamping force is retained completely, even in the event of pressure loss. For safety reasons it is recommended to maintain the hydraulic pressure. To unclamp, depressurise port A and apply pressure to port B. The mechanical lock is released and the clamping element moves to the unclamping position.

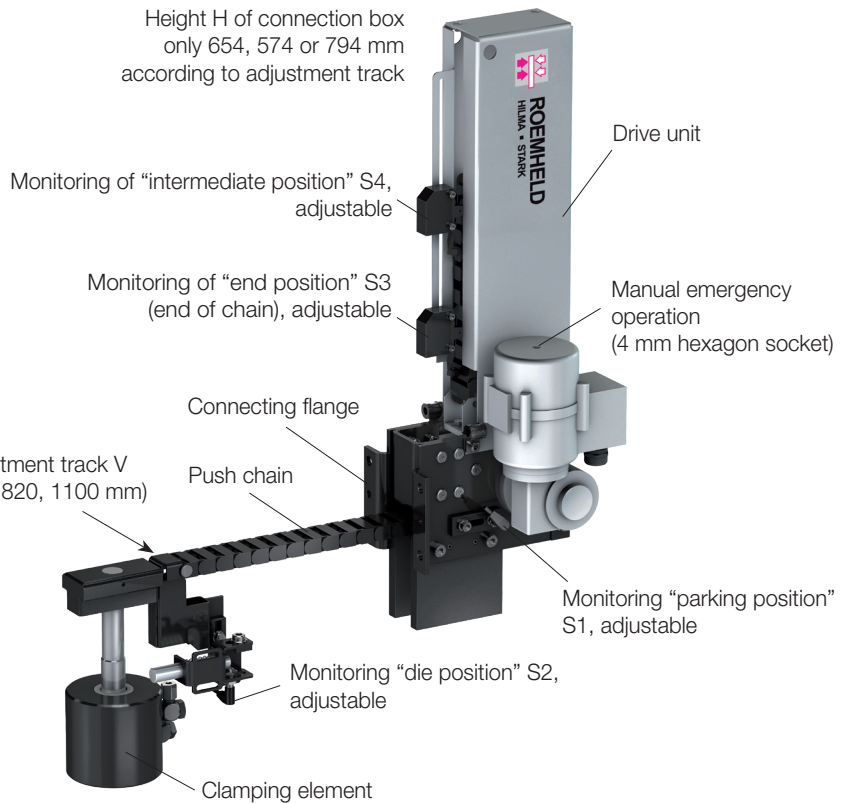

Electrical interface

Harting connector for motor + position monitoring
 Pin assignment and connector version see circuit diagram
 (special version or without connector on request)

Pneumatic interface (air motor)

Port R to move the clamp forward (to the die)
 Port L to move the clamp backward (to the parking station)
 Connecting thread G 1/4 (plug-in connectors included in the delivery)
 Operating pressure 6 up to 7 bar
 Air supply hose Ø LW 6 mm (external Ø 8 mm)

Hydraulic interface

Port A for clamping
 Port B for unclamping
 Standard: M16x1.5 union nut
 Pipe connection Ø 8 mm

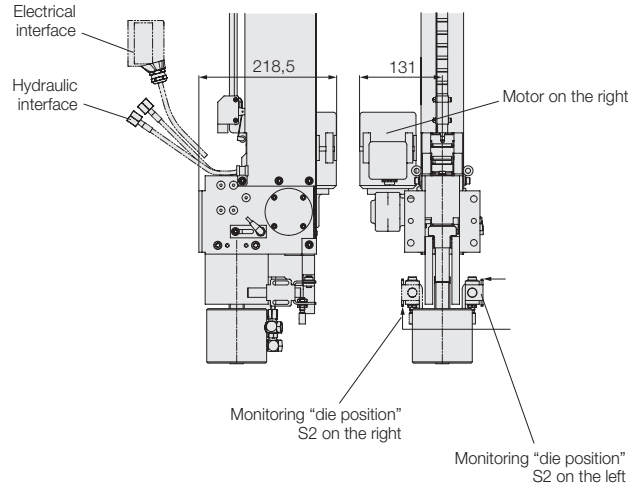

Pin assignment of the Harting connector versions

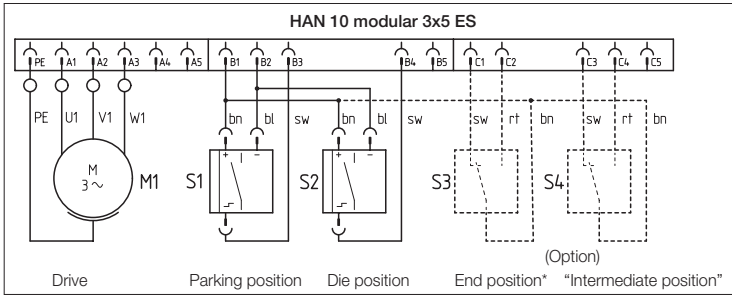

Pin assignment

for pneumatic motor:
HAN 10 ES (presentation on request)

for direct current motor 24 V DC:
HAN 10 ES (presentation on request)

for single-phase alternating current motor 115 V AC, 60 Hz:
HAN 6 ES / HAN 10 ES (presentation on request)

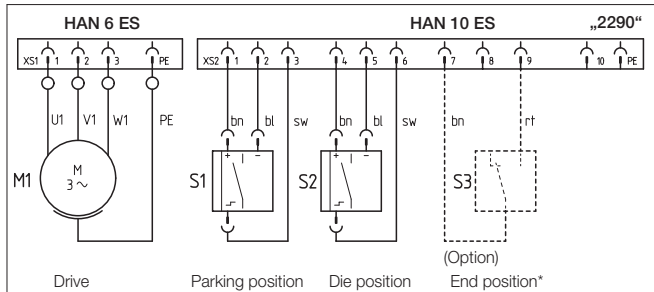
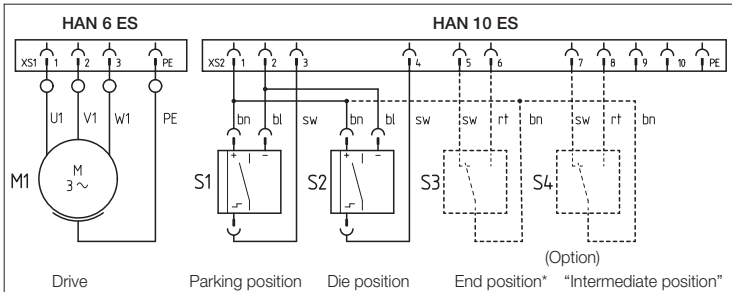
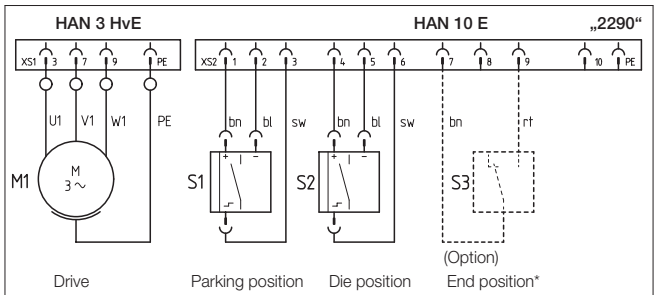
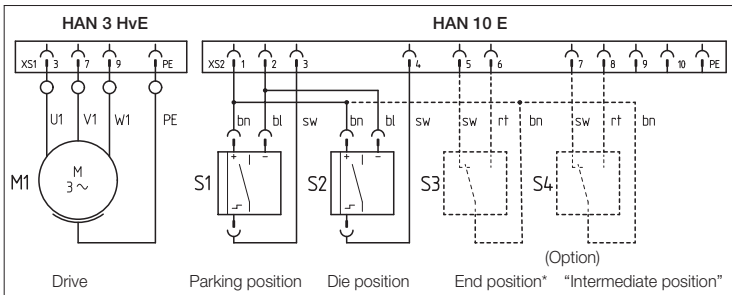

*) not actuated in * position!

Special versions of the rapid clamping system

Please contact us if your individual clamping task is not covered by the options available with "Flexline". In many cases, we will be able to fulfill your requirements with a customised special version which deviates only slightly from the standard design.

Possible special versions:

- Clamping solutions for tight spaces
- Special mounting hole pattern
- Different T-slot dimension (e.g. T-slot 22)
- Modified adjustment track V (e.g. > 1100 mm)
- Clamping elements with for example:
 - special clamping force
 - specific operating pressure
 - modified clamping stroke St
 - modified clamping dimension F
 - modified shape
 - different mode of operation
- Different motor voltage (e.g. 24 V DC) or different drive principle (e.g. pneumatic)
- Special options for electric or hydraulic connections
- Components of certain manufacturers or specifications
- Additional requests and customer-specific requirements ...

Examples of possible special versions

Special sliding clamp with two clamping pistons

- short track

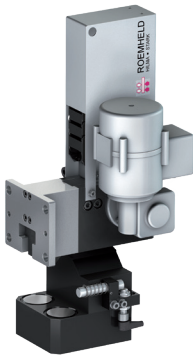

Adaptor plate with special mounting hole pattern

- special electric and hydraulic connection

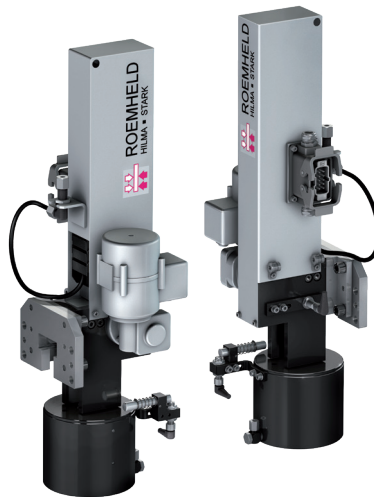

Long track with special low profile chain case

- additional position monitoring



Special flange plate with special mounting hole pattern

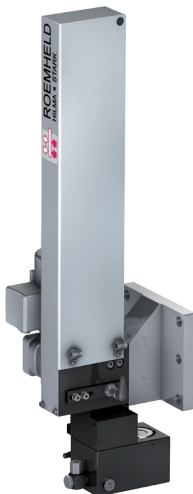

Additional extension bracket with new parking position to overcome major obstruction on the press



